



Progress Supply Inc.

The

Progress Report

Helpful Information for HVAC/R & Controls Contractors from Progress Supply Inc.

WHAT'S THE BIG DEAL ABOUT THERMAL EXPANSION VALVES (TXV)

The increasingly important **Thermal Expansion Valve (TXV)** is getting much more attention in today's realm of cooling and refrigeration.

Here's Why

With the recent changes to 13 **SEER*** (**Seasonal Energy Efficiency Ratio**) ratings for all residential air conditioners manufactured after early 2006, their use has been expanded. No longer found on just commercial HVAC and larger refrigeration systems, they now can be found in residential, commercial and industrial cooling and refrigeration units.

The TXV regulates the flow of refrigerant to maximize the efficiency of the evaporator at all operating conditions, whereas a fixed orifice can only be optimized at one particular condition. For this reason, if energy efficiency is the goal, a system incorporating a TXV should be specified.

Valuable Tech Tips

Progress Supply has taken some of the most commonly asked questions about TXVs from **Emerson Climate Technologies** service tip cards, together with the answers to those questions, and included them in this issue of **The Progress Report**. We plan to have additional TXV Tech Tips in subsequent issues, as well.

Where possible, the answers are generic but, in some cases, reference is made to specific Thermal Expansion Valves — in most cases, these are FlowControl Valves from **Emerson Climate Technologies**. These *Tech Tips* cover a variety of topics and will, hopefully, add to your knowledge of TXVs.

You may want to hang onto this issue as a handy reference guide should any questions arise about TXVs.

If you do have questions concerning TXVs and their application and operation, and need help, feel free to contact your Progress Supply Technical Support Representative at our branches in Cincinnati, Dayton or Columbus.

The **SEER (Seasonal Energy Efficiency Ratio) is a measure of how efficiently an air conditioner or heat pump will operate over an entire cooling season instead of only a single operating condition.*

CONTRACTOR THERMAL EXPANSION VALVE SERVICE TIPS

TIP 1

TXV Selection

Q: How do I select a TXV for a particular application?

In order to make an accurate TXV selection, it is necessary to match the flow rate (in tons) of the TXV to the tonnage rating of the evaporator coil. The following procedure is recommended:

- ◆ Determine system refrigerant
- ◆ Determine tonnage rating of the evaporator coil at the operating temperature
- ◆ Determine liquid refrigerant temperature at the TXV inlet
- ◆ Calculate the pressure drop across the TXV by subtracting suction (low side) pressure from condensing (high side) pressure. Also subtract pressure drop from a distributor, if one is used. The difference is pressure drop across the TXV.
- ◆ Find the proper extended capacity table in the catalog for the correct refrigerant at the proper evaporator temperature. Then locate the closest pressure drop column and find the nearest flow rate in tons (to the evaporator tonnage). Go to the left to select the nominal tonnage rated valve. You will have to recalculate the flow rate in tons using the Liquid Correction Factor Table if the actual liquid temperature is different from 100F used as the standard rating point.

TIP 2

Quick Facts — Maximum Operating Pressure (MOP)

Q: What does MOP (Maximum Operating Pressure and/or Motor Overload Protection) mean on an expansion valve?

MOP refers to the maximum value that the suction pressure is allowed to rise to before the expansion valve tends to close off and restrict a further increase in flow. This is accomplished at the point where the gas in the expansion valve's power element charge has become superheated and can exert only slightly more opening pressure as the temperature rises.

The purpose of MOP is to prevent the suction pressure from rising so high that the compressor motor cannot start due to too high of an initial load.

An MOP type valve tends to serve the same function as a crankcase pressure regulating (CPR) valve; however, it will not control as precisely as the CPR valve. It usually is not recommended to use both a CPR and an MOP type valve on the same system as there is a possibility that they will 'fight' each other as they both try to control.

TIP 3

Quick Facts — Bi-Flow TXV

Q: Does an HFES (or other balanced port TXV) bi-flow work on a heat pump system?

The HFES series (or other balanced port valve) will meter the flow of refrigerant in either direction. The sensing bulb in such a case would have to be located on a common suction line, such as the center tube of a 4-way valve (see figure 1).

Also, for such a system to work properly, the system would have to be 'closed coupled,' meaning that the evaporator and condenser would have to be physically located in close proximity to one another, such as in a packaged system.

For 'split' type systems, the long length of tubing between the TXV and the coils makes it impractical to utilize an approach of this type.

For such systems, two expansion valves must be used; one on the indoor and one on the outdoor coil. Check valves must be installed around each of the TXVs to allow flow around the valve when operating in the reverse direction (see figure 2).

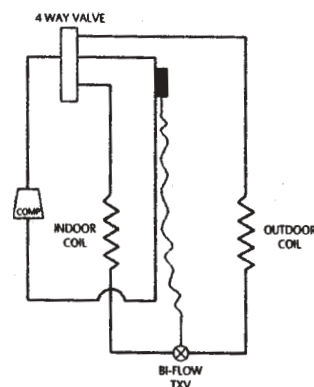

FIGURE 1 - PACKAGED SYSTEM

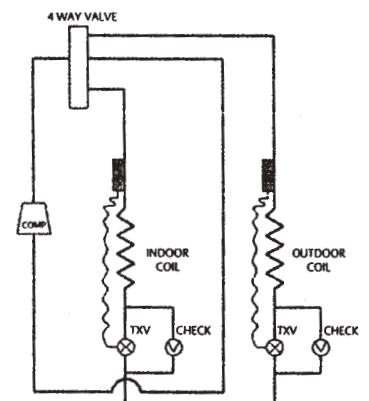

FIGURE 2 - SPLIT SYSTEM

TIP 4

Quick Facts – Internal or External Equalized TXV

Q: What is the difference between an 'internally' equalized and 'externally' equalized TXV?

An internally equalized TXV uses evaporator inlet pressure to create the 'closing' force on the valve. An externally equalized valve uses the evaporator outlet pressure, thereby compensating for any pressure drop through the evaporator.

If an internally equalized valve is used in a system with a large pressure drop through the evaporator, the pressure below the diaphragm will be higher, causing the valve to go in a more 'closed' position and resulting in a superheat higher than desired (starving).

Q: When should I use an externally equalized TXV?

1. On any large system, generally over 1 ton capacity.
2. On any system utilizing a distributor

Note: For field replacement, you can always replace an internally equalized valve with an externally equalized type; however, you should never replace an externally equalized valve with an internal type.

Q: If I need to replace an internally equalized valve and all that is available is an externally equalized type, can I simply 'cap' the equalizer fitting?

No, the equalizer must be connected to the suction line near the thermal bulb. Capping the equalizer line will prevent the valve from operating properly.

Q: Will an externally equalized TXV allow system pressures to 'equalize' during off cycles?

No, an externally equalized valve will NOT allow system high and low sides to 'equalize' during the off cycle. The only way this can be accomplished is through the use of a 'bleed' type TXV.

Q: Where should the external equalizer be installed?

The external equalizer line should be installed on top of the suction line before any traps and located within 6 inches of the sensing bulb position. If this is not possible, and a different location is required, it must first be confirmed that the pressure at the desired location is identical to the pressure at the bulb.

Q: What happens if the equalizer tube becomes 'kinked'?

If the equalizer line becomes 'kinked' the pressure sensed at the underside of the diaphragm will no longer correspond to the evaporator outlet pressure and the valve will not be able to operate as intended.

Q: I have seen some equalizer tubes 'frosted.' Is that normal?

Frost on the equalizer line is an indication that the packing seal has failed, allowing higher pressure refrigerant to leak past and expand into the equalizer line. Depending on the valve type, either the cage assembly or the entire valve should be replaced.

TIP 5

Sensing Bulb Location

Q: What is the correct position for the TXV sensing bulb?

The placement of the remote sensing bulb of the TXV onto the suction line is critical to proper TXV performance. The important points to follow are:

- ◆ Clean the suction line near the outlet of the evaporator
- ◆ The entire length of the sensing bulb must be in contact with the cleaned portion of the suction line
- ◆ The sensing bulb should be placed several inches downstream of the external equalizer connection
- ◆ The sensing bulb should be attached at 12 o'clock on any suction line of 7/8" diameter or smaller. On lines larger than 7/8" diameter, the bulb should be placed at either 4 or 8 o'clock. The bulb should never be placed at 6 o'clock
- ◆ Always insulate the sensing bulb after installation
- ◆ A sensing bulb can be installed on a vertical suction line, if necessary, but never place bulb downstream of a trap. Bulb placement before a trap (upstream) is recommended.

See graphic.

POSITIONING THE TXV SENSING BULB

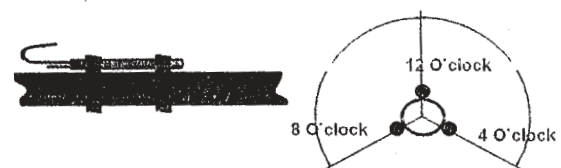

- On suction lines less than 7/8" diameter, position bulb at 12:00 o'clock
- On suction lines greater than 7/8" diameter, position bulb at 4 or 8 o'clock

EMERSON.
Climate Technologies